

UNCONTROLLED IF PRINTED; CONTROLLED COPY LOCATED IN IQMS DOCUMENT CONTROL

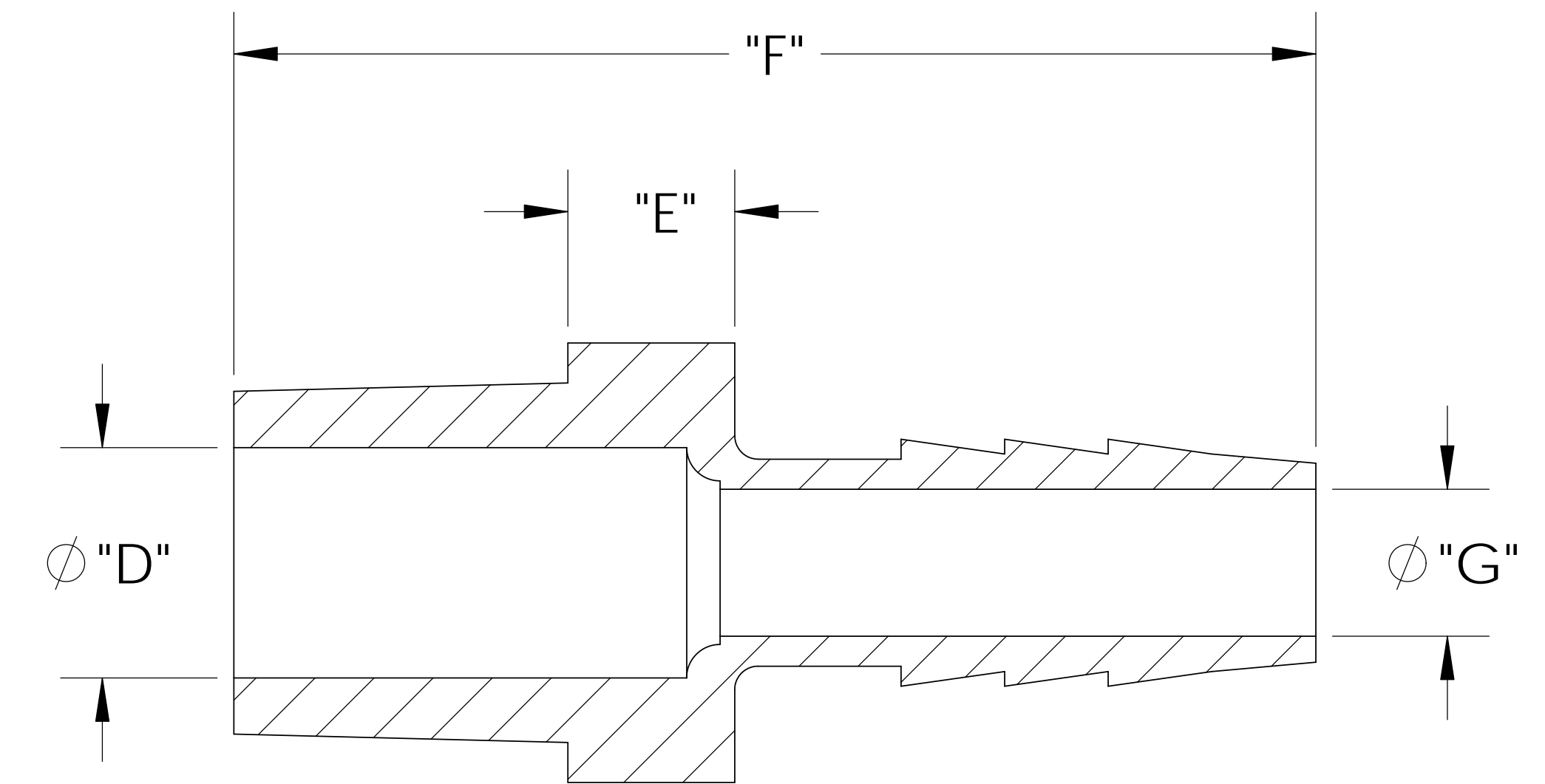
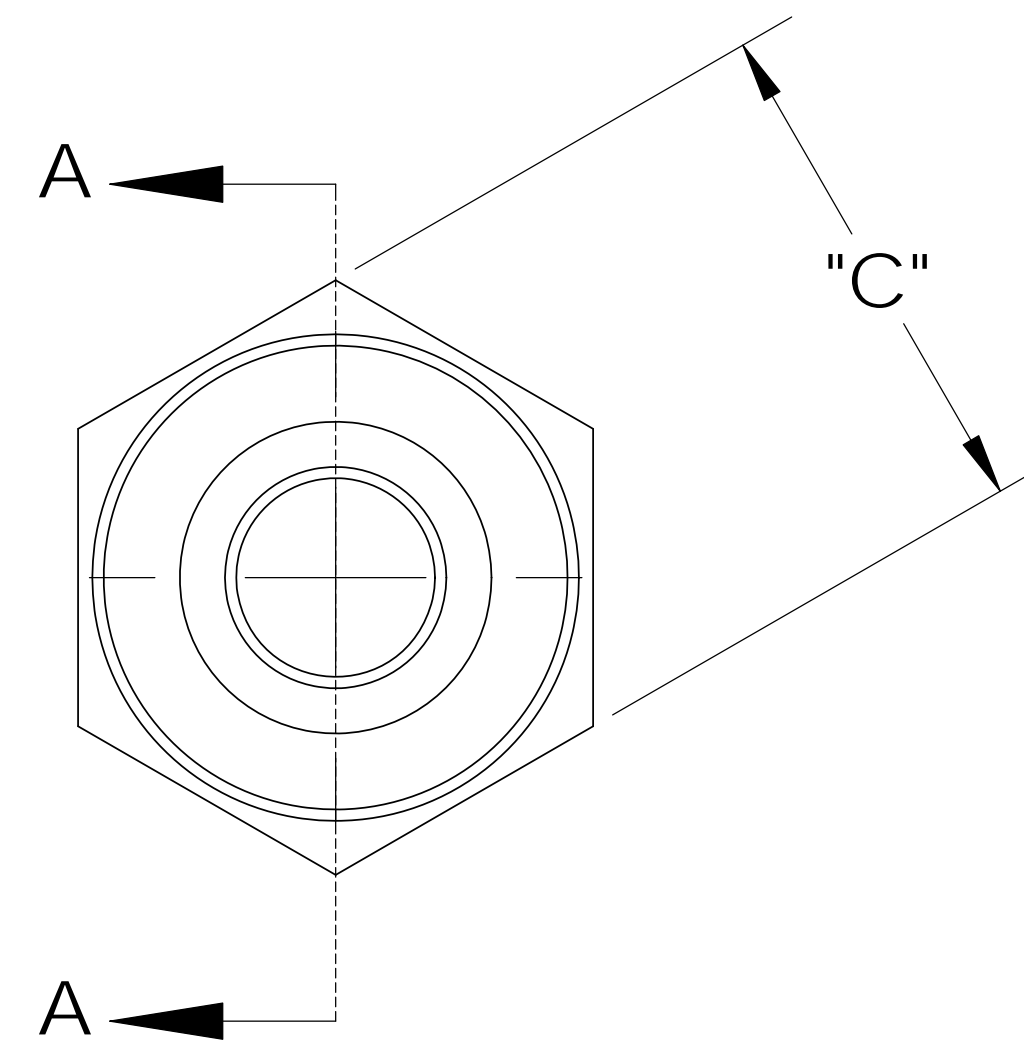
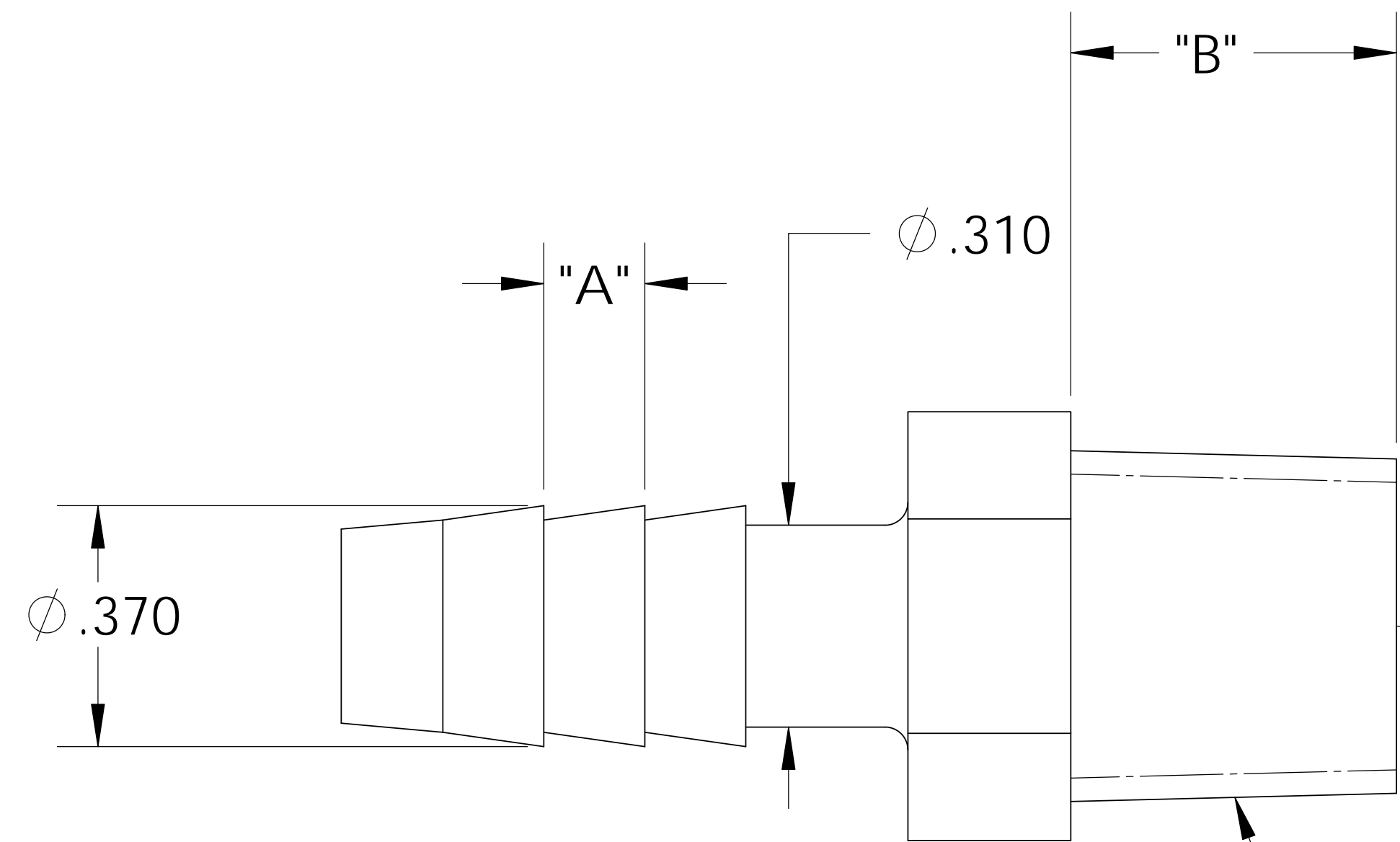
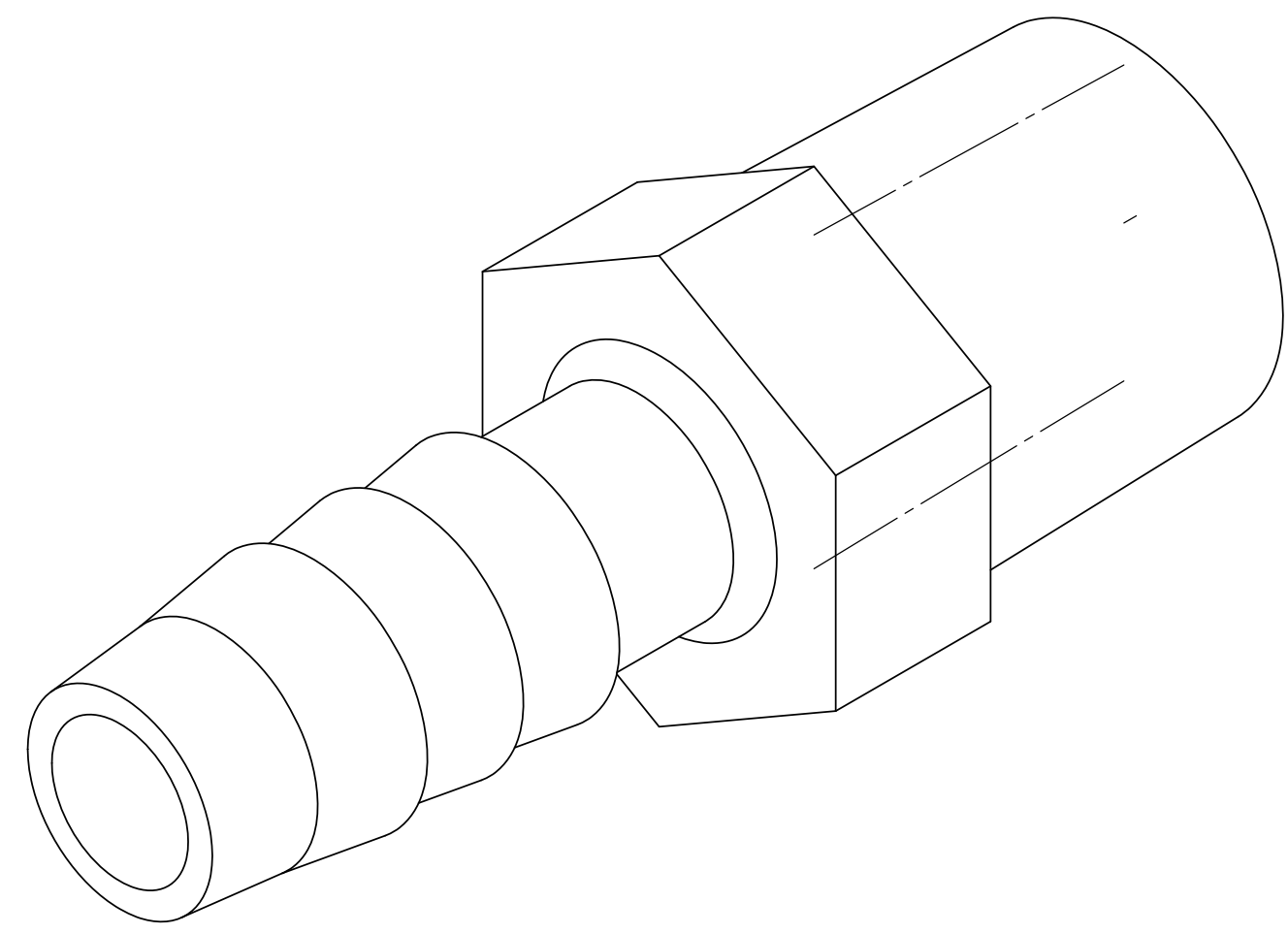

SECTION A-A

MALE 1/4"-18 NPT

CATALOG NO.	DESCRIPTION	MATERIAL	DIM "A"	DIM "B"	DIM "C"	DIM "D"	DIM "E"	DIM "F"	DIM "G"
TA1045/PP	1/4" NPT X 5/16" PP	POLYPROPYLENE	.155	.50	.56	.335	.250	1.60	.215
TA1045/P	1/4" NPT X 5/16" P	POLYETHYLENE	.145	.49	.55	.330	.245	1.60	.215
TA1045/N	1/4" NPT X 5/16" N	NYLON	.155	.50	.57	.345	.250	1.62	.220

SHOWN

NOTES:

- 1) POLYPROPYLENE HAS COLOR OPTIONS:
BLACK = TA1045/PPB
NATURAL = TA1045/PPN

PROPRIETARY AND CONFIDENTIAL
THE INFORMATION CONTAINED IN THIS DRAWING IS THE SOLE PROPERTY OF THOGUS PRODUCTS COMPANY. ANY REPRODUCTION IN PART OR AS A WHOLE WITHOUT THE WRITTEN PERMISSION OF THOGUS PRODUCTS COMPANY IS PROHIBITED.

REV	WRO#	DESCRIPTION
E	95.00072	CONVERTED TO 3D FORMAT
HISTORY		

UNLESS OTHERWISE SPECIFIED:
DIMENSIONS ARE IN INCHES
TOLERANCES:
ANGULAR: ±0.5°
X.X = ± 0.1
X.XX = ± 0.05
X.XXX = ± 0.015
REMOVE ALL SHARP EDGES AND BURRS
BLEND ALL RADII TO 0.01IN
INTERPRET GEOMETRIC TOLERANCING PER: ANSI Y 14.5 1994
MATERIAL: PP, P, N
FINISH: NA
THIRD ANGLE PROJECTION:

	NAME	DATE
DRAWN	JRM	03/17/11
CHECKED	KDJ	3/17/11
ENG APPR.		XX/XX/XX
MFG APPR.		XX/XX/XX
Q.A.		XX/XX/XX

Thogus You think it, we can make it...
33490 PIN OAK, AVON LAKE, OH 44012

TITLE: **1/4" NPT X 5/16" BARB ADAPTER**

SIZE B	DWG. NO. TA1045	REV E
SCALE: 2:1	MASS:	SHEET 1 OF 1

DO NOT SCALE DRAWING